

Sara Stedy

Instructions for Use

ARJOHUNTLEIGH
GETINGE GROUP



CE

...with people in mind

Design Policy and Copyright

® and ™ are trademarks belonging to the ArjoHuntleigh group of companies.

© ArjoHuntleigh 2014.

As our policy is one of continuous improvement, we reserve the right to modify designs without prior notice. The content of this publication may not be copied either whole or in part without the consent of ArjoHuntleigh.

Table of Contents

General Information	5
Foreword	5
Service and Support	5
Manufacturer Information	6
Definitions Used in this Manual	6
Intended Use	6
Conditions	6
Operational Life	7
Equipment Identification	7
Verifying the Package Contents	7
Policy on Number of Staff Members Required for Patient Transfer	7
How to Use this Manual	7
Symbols Used	8
Safety Instructions.....	9
General Instructions	9
Safe Working Load	9
Important Safety Directions	9
Equipment Warning Labels	10
Slings.....	12
Compatible Slings	12
How to Use the Sara Steady.....	13
Using the Sling Attachment Lugs	13
Pivoting the Cushions	13
Opening and Closing the Legs	14
Applying and Releasing the Brakes on the Rear castors	14
Approaching the Patient	15
Before Transferring the Patient	15
Transferring the Patient	16
Transferring the Patient from a Chair	16
Transferring the Patient to a Chair	17
Transferring the Patient from a Wheelchair	18
Transferring the Patient to a Wheelchair	19
Transferring the Patient from a Bed	20
Transferring the Patient to a Bed	21
Transferring the Patient from a Toilet	22
Transferring the Patient to a Toilet	23
Transferring the Patient at the Toilet	23
Back Support Strap	24
Using the Back Support Strap	24
Care and Maintenance	25
Preventive Maintenance Schedule	25
User Inspections	25
Inspection and Cleaning	27
Sling Inspection and Care	27
Annual Inspection	27

Table of Contents

Troubleshooting	28
Labels on the Sara Stedy	29
Technical Specifications	30
Lift Dimensions	31

General Information

Thank you for purchasing the Sara Stedy floor lift from ArjoHuntleigh.

Your Sara Stedy is part of a series of quality products designed specially for hospitals, nursing homes and other health care uses.

We are dedicated to serving your needs and providing the best products available along with training that will bring your staff maximum benefit from every ArjoHuntleigh product.

Please read this manual thoroughly, and contact us if you have any questions about the operation or maintenance of your ArjoHuntleigh equipment.

Foreword

Please read this manual in its entirety before using your Sara Stedy. The information in this manual is crucial to the proper operation and maintenance of the equipment, and will help protect your product as well as ensure that the equipment performs to your satisfaction. Some of the information in this manual is important for your safety and must be read and understood to help prevent injuries. ArjoHuntleigh strongly advises and warns that to avoid injuries that can be attributed to the use of inadequate parts, only parts designated by ArjoHuntleigh should be used on equipment and other appliances supplied by ArjoHuntleigh.

Furthermore, unauthorized modifications on any ArjoHuntleigh equipment may affect its safety. ArjoHuntleigh will not be held responsible for any accidents, incidents or deficiencies of performance that occur as a result of any unauthorized modification to its products.

Tested according to standards by: ISO10535:2006

Service and Support

A service routine must be performed on your Sara Stedy by qualified service personnel. This will ensure the safety and good functioning of your product. See section called “Care and Maintenance” in this manual.

If you require further information, please contact your representative which can offer comprehensive support and service programs to maximize the long-term reliability, safety and value of the product. Contact your local representative for replacement parts.

Additional copies of this manual can be ordered from your local ArjoHuntleigh representative. When ordering, include the *Instructions for Use* product number (see front page) and equipment identification number.

General Information

Manufacturer Information

This product has been manufactured by:

ArjoHuntleigh AB

Hans Michelsensgatan 10

211 20 Malmö,

SWEDEN

Definitions Used in this Manual

WARNING:

Means: Failure to understand and follow these instructions may result in injury to yourself and others.

CAUTION:

Means: Failure to follow these instructions may cause damage to the product.

NOTE:

Means: This is important information regarding the correct use of the equipment.

Intended Use

The Sara Stedy is a mobile active lift with a safe working load (SWL) of 182 kg (400 lb). It is intended to be operated on horizontal surfaces for transferring patients and residents in hospitals, nursing homes or other health care facilities.

This lift is intended to be used only by patients who have the ability to stand unaided or who can stand with minimal assistance.

The Sara Stedy may also be used as a supportive aid when elevating a patient for the purposes of changing wound dressings, incontinence pads or for personal cleansing.

The Sara Stedy is manufactured to a very high standard and has been designed to

quickly and easily transport or transfer patients from one sitting position to another. It is not intended for long periods of sitting or transfer.

The Sara Stedy is intended to transfer a patient to/from a chair, a wheelchair, a bed and a toilet.

Any references to the “patient” in this document apply equally to a resident at home or in a long term care facility and refer to the person transferred.

References to left or right in these instructions are as viewed from the caregiver’s pushing position, standing at the rear of the Sara Stedy, facing forward.

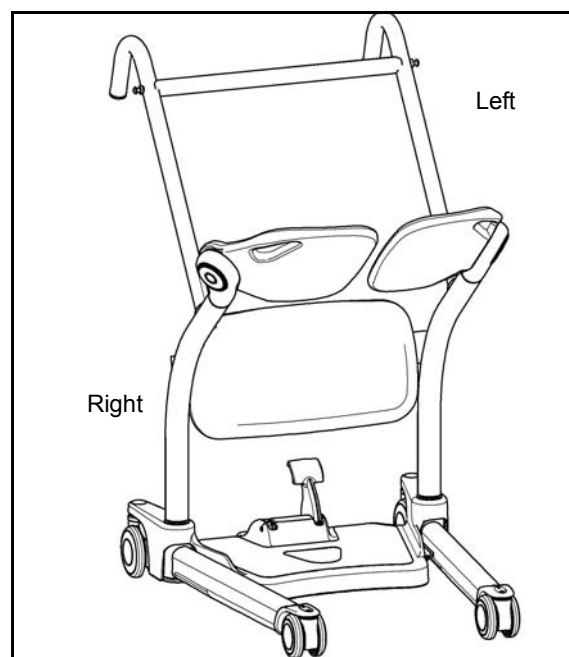

Fig. 1

Conditions

- The unit is cared for and serviced in accordance with recommended, published *Instructions for Use*.
- The unit is maintained to the minimum requirements as published in the “Preventive Maintenance Schedule” section of this manual.
- The servicing and product care, in accordance with ArjoHuntleigh requirements, must begin on first use of the unit by the customer.

General Information

- The equipment must be used for its intended purpose only and is operated within the published limitations. Only ArjoHuntleigh designated spare parts should be used.

Operational Life

The expected operational life of your ArjoHuntleigh lift is ten (10) years from the date of manufacture, providing the following conditions are adhered to:

- The expected operational life for fabric slings and fabric stretchers is approximately two years from date of purchase.
- This life expectancy only applies if the slings and stretchers have been cleaned, maintained and inspected in accordance with the “ArjoHuntleigh Sling Information” documents, the “Instructions for Use” and the “Preventive Maintenance Schedule”.

WARNING: The manufacturer cannot ensure full safety for a floor lift or an accessory of which the life span has been exceeded.

Equipment Identification

The unit's identification number (specification, model, serial number) appears on a silver nameplate affixed on the side of the frame.

Verifying the Package Contents

Upon receipt of the equipment, verify it against the packing list to ensure it is complete and inspect the equipment for possible damage due to shipping. If there is any damage, notify the carrier immediately to file a claim. Provide complete information concerning damage claims or shipping errors to your local ArjoHuntleigh representative. Include all equipment identification numbers and group part numbers (if any) as described above along

with a full description of damaged parts.

Policy on Number of Staff Members Required for Patient Transfer

ArjoHuntleigh's passive and active series of lifts are designed for safe usage with one caregiver. There are circumstances, such as combativeness, obesity, contractures, etc., of the patient that may dictate the need for a two-person transfer. It is the responsibility of each facility or medical professional to determine if a one or two-person transfer is more appropriate, based on the task, patient load, environment, capability, and skill level of the staff members.

How to Use this Manual

WARNING: Do not attempt to use this equipment without fully understanding the information contained in this manual.

To ensure the safe operation of the Sara Stedy, read the entire manual carefully, especially the “Safety Instructions” section, before installing, operating, or servicing this equipment.

If anything is not completely understood, please contact your local ArjoHuntleigh representative for more details. Failure to comply with warnings in this manual may result in injuries.

Keep this manual with the lift and refer to it as required. Make sure that all operators are regularly trained in the use of the equipment according to the information found therein.

General Information

Symbols Used







Symbol	Key to symbols
	This symbol is accompanied by a date to indicate the date of manufacture and by the address of the manufacturer.
	This symbol indicates the products comply with the medical device directive 93/42/EEC.
	This symbol is accompanied by the manufacturer's catalogue number.
	This symbol is accompanied by the manufacturer's serial number.
	This symbol refers to the <i>Instructions for Use</i> .
	This symbol indicates a risk of pinching.

Fig. 2

Safety Instructions

The equipment must be used in accordance with these safety instructions.

Anyone using the equipment must also have read and understood the instructions in this manual.

If there is anything you are not sure about, contact your local ArjoHuntleigh representative.

General Instructions

Keep these safety instructions with the unit at all times.

Read the *Instructions for Use* before installing, operating, or servicing this equipment.

WARNING: The Sara Stedy is for transferring patients only. Do not use the lift for any other purpose.

WARNING: Always place the sling around the patient according to the instructions enclosed. Failure to do so may result in injuries to you or to others.

Safe Working Load

The Sara Stedy has been designed with a capacity of 182 kg (400 lb).

WARNING: The Sara Stedy is intended to be used for patients whose weight is within a specified safe working load. Do not attempt to lift more than the weight limit indicated on the “maximum load” label on the lift.

Important Safety Directions

- Always carry out the recommended daily maintenance before using the lift.
- Always maneuver the Sara Stedy by using the handles. Do not push on the legs.

Safety Instructions

WARNING: Before attempting a transfer, a clinical assessment of the patient's suitability for transfer should be carried out by a qualified health professional considering that, among other things, the transfer may induce substantial pressure on the patient's body.

Equipment Warning Labels

Inspect all precautionary labels on the equipment. Order and replace all labels that cannot be easily read.

- Ensure that you are prepared before attempting to transfer a patient.
- Do not attempt to push or pull a loaded lift over a floor obstruction which the castors are unable to ride over easily, including steps, door thresholds or moving sidewalk.
- Do not push the lift at a speed which exceeds a slow walking pace (3 km/hour or 0.8 meter/second).
- An assessment of the suitability for transfer of a patient who is connected to electrodes, catheters or other medical devices must be conducted by qualified personnel before performing the transfer.
- This mobile patient lift must be used by a caregiver trained with these instructions and qualified to work with the patient to be transferred and should never be used by patients on their own.
- Avoid any impact during transfer.
- Ensure the sling is intended to be used for this lift and can take the weight of the patient.
- Ensure the sling is not damaged, torn or frayed.
- Ensure the sling straps are in good condition and properly fastened.
- Replace any precautionary or instruction labels that cannot be easily read.

Part Designation

Sara Steady

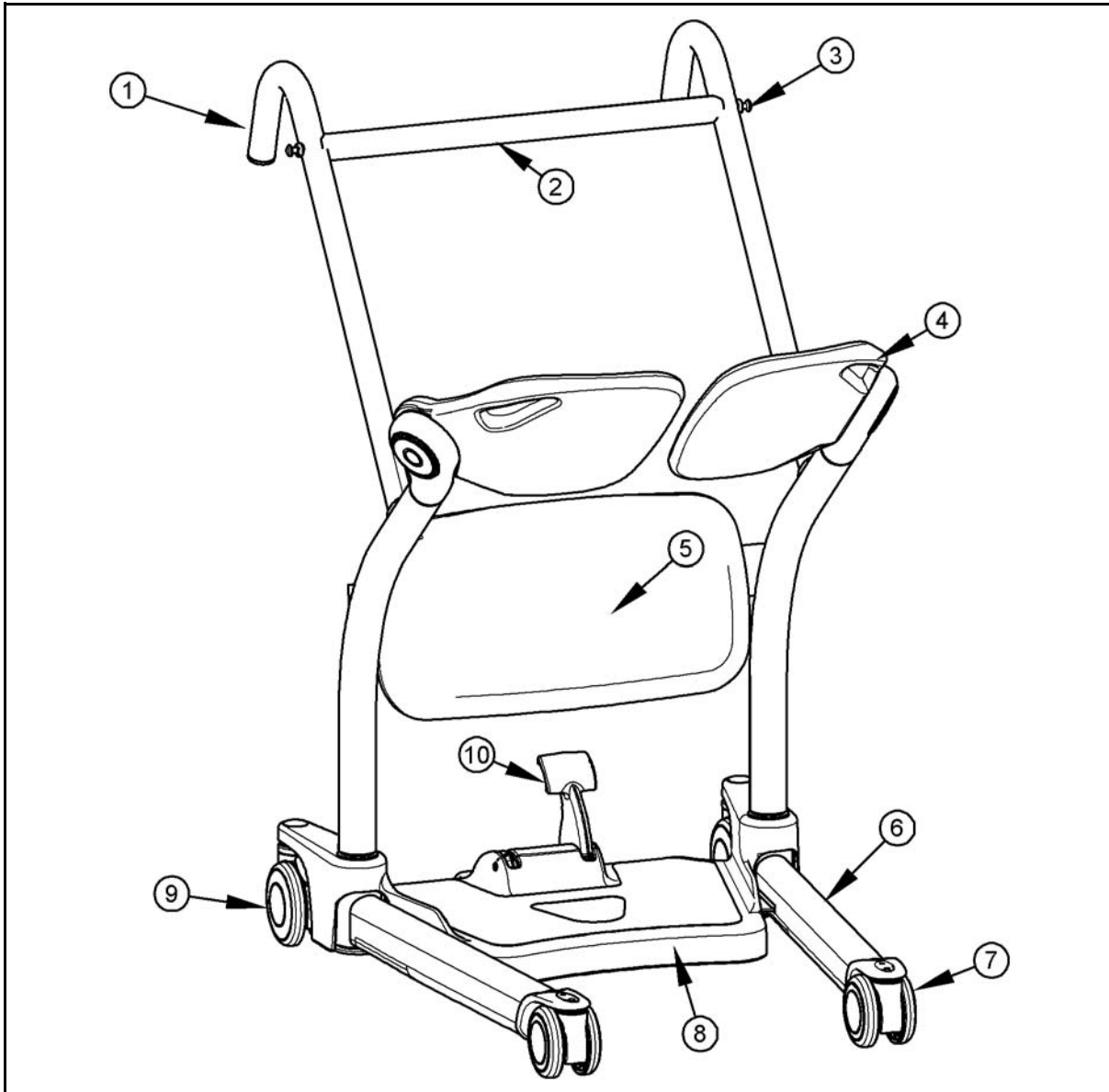

Fig. 3

Legend

- | | |
|-------------------------------------|---------------------------------|
| 1) Manoeuvring handles | 7) Front castor |
| 2) Crossbar / Handle bar | 8) Footboard / Base |
| 3) Sling attachment lugs | 9) Rear castor with brake |
| 4) Pivoting seat halves / Seat pads | 10) Leg pivot footlever / Pedal |
| 5) Kneepad | |
| 6) Leg | |

Slings

Compatible Slings

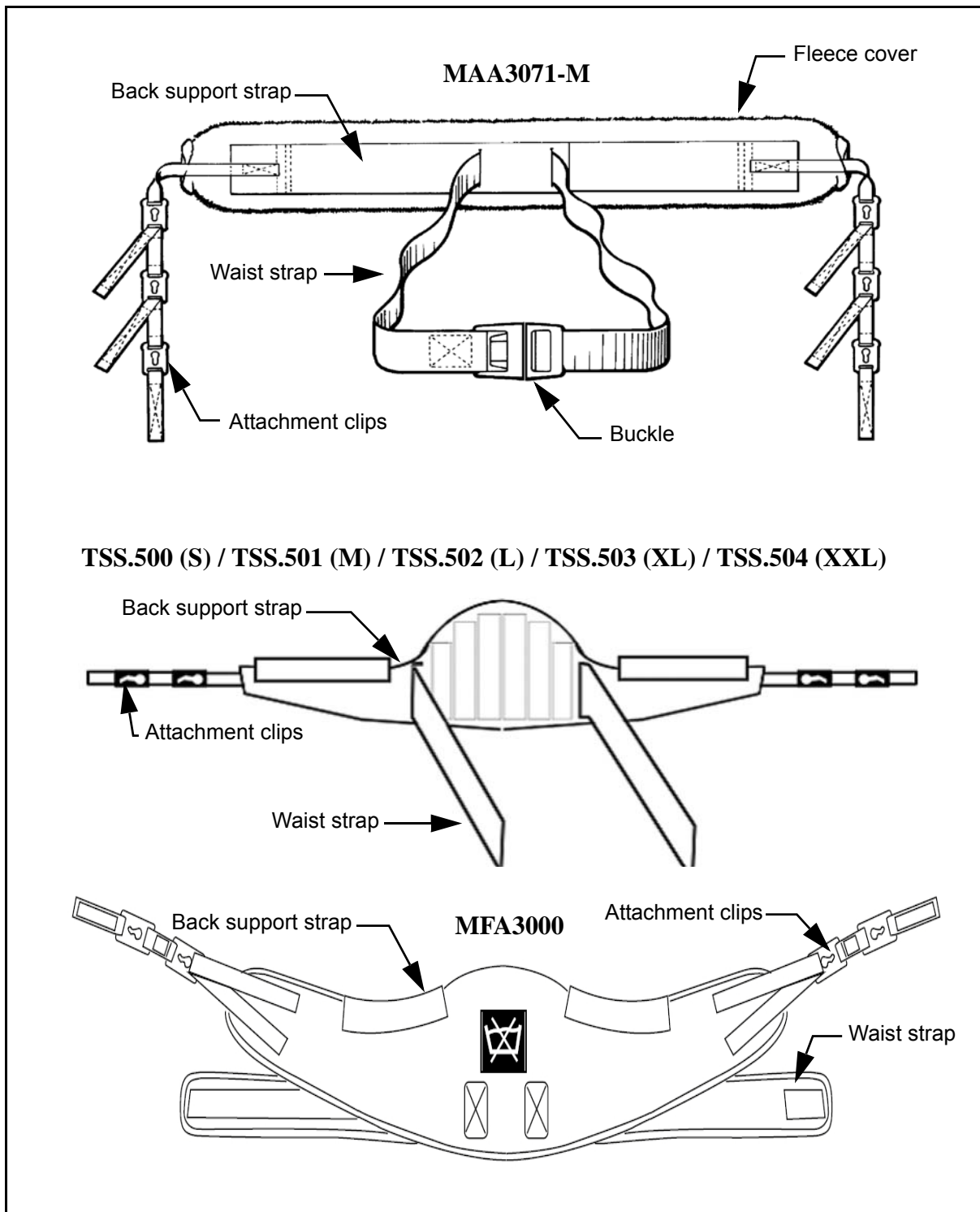

Fig. 4

For more information about sling use, please refer to the documentation that comes with your sling.

How to Use the Sara Steady

NOTE: Use of sling is optional and dependent on patient assessment.

Using the Sling Attachment Lugs

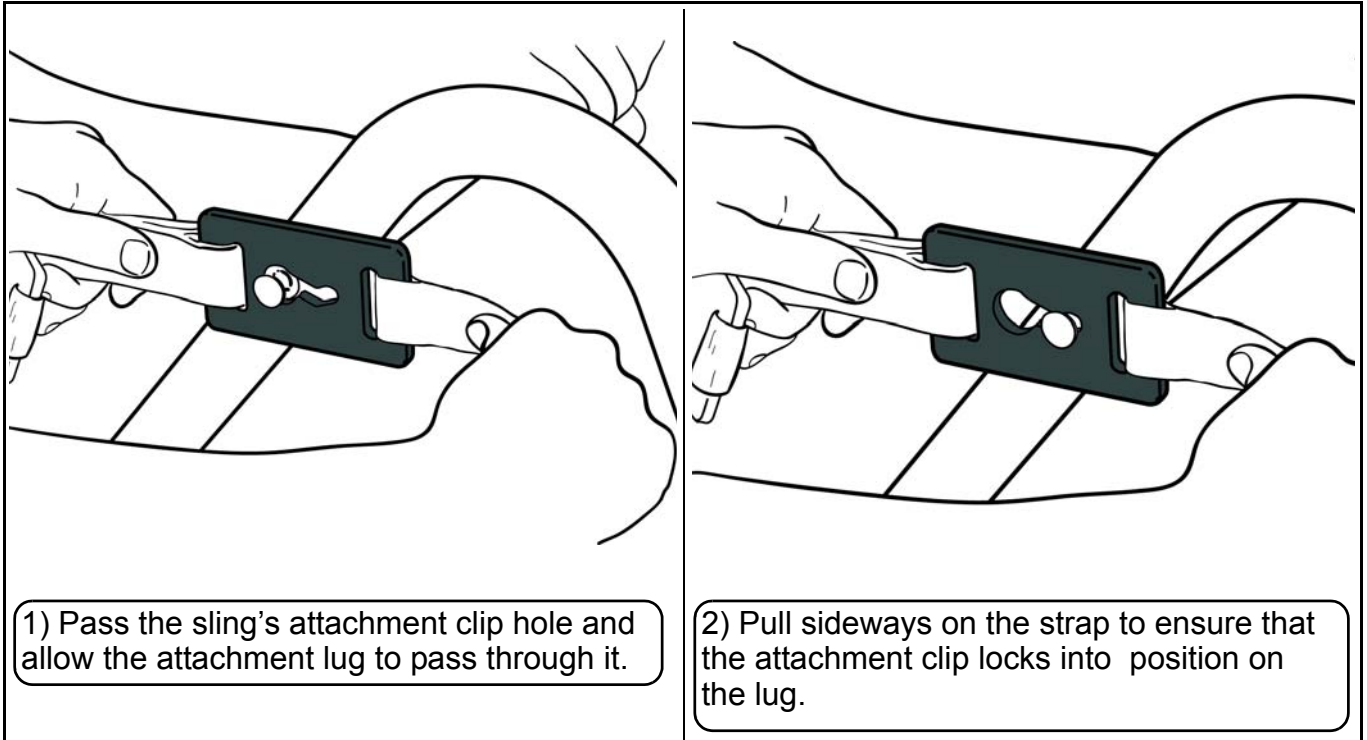

Fig. 5

Pivoting the Cushions

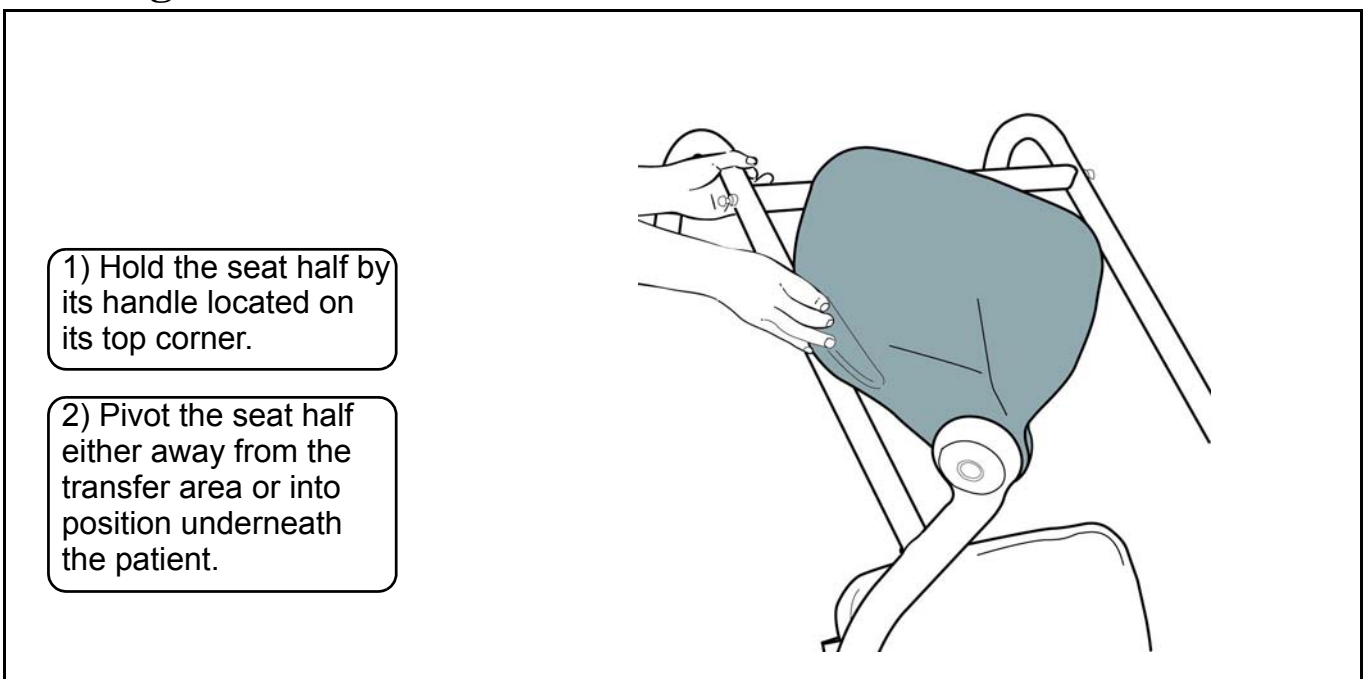

Fig. 6

How to Use the Sara Steady

Opening and Closing the Legs

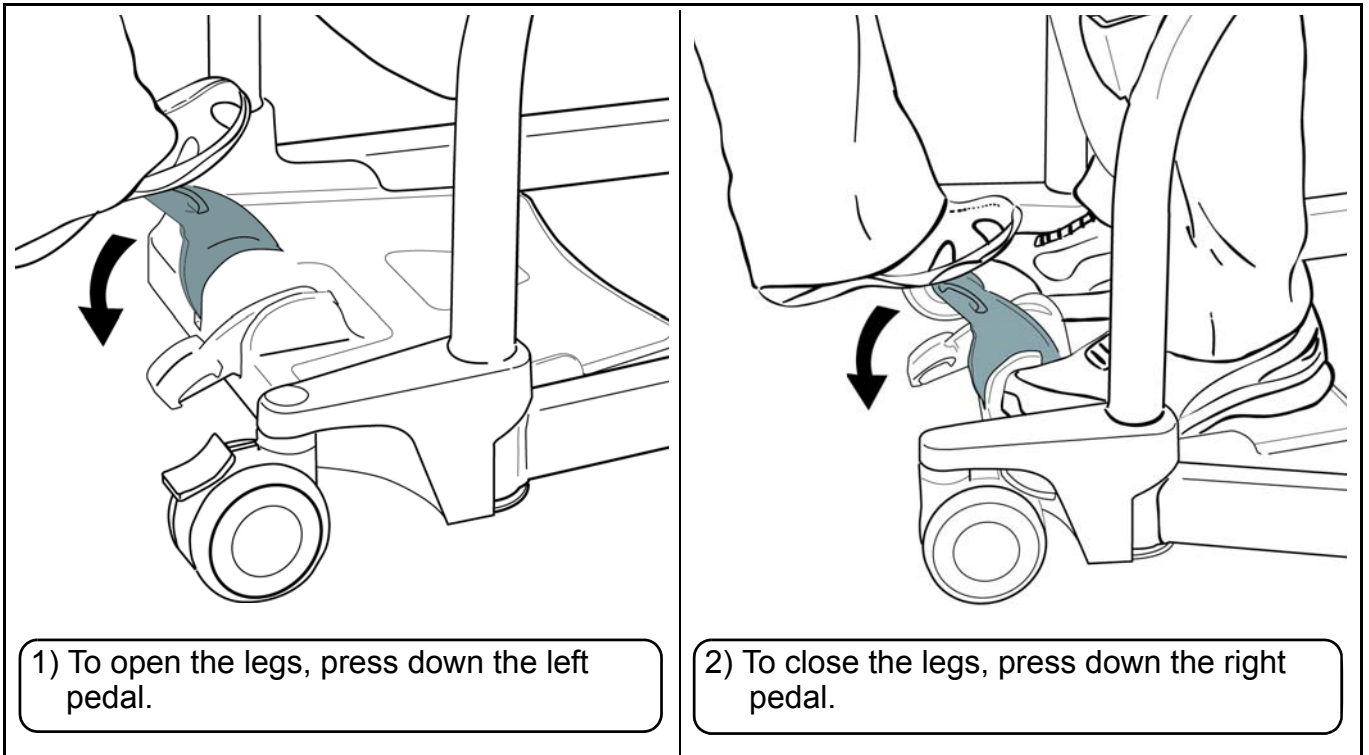

Fig. 7

Applying and Releasing the Brakes on the Rear Castors

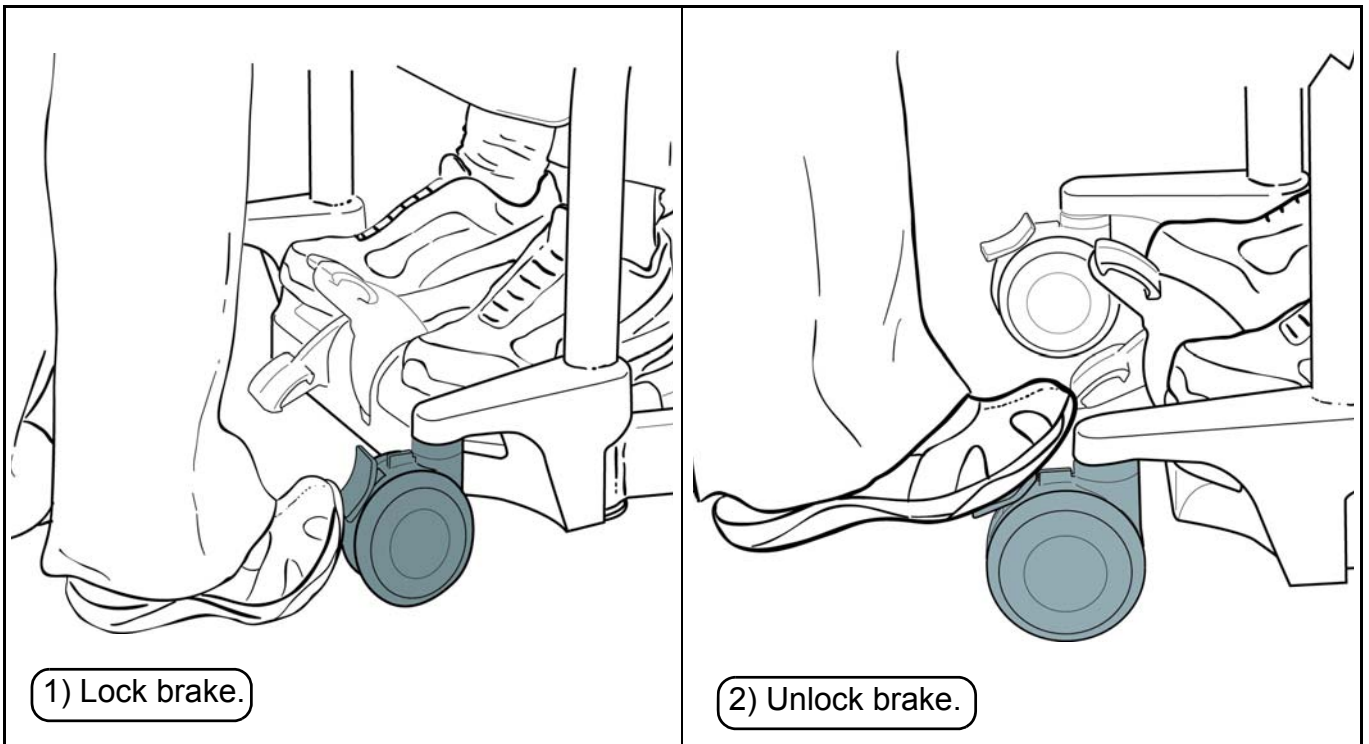

Fig. 8

How to Use the Sara Stedy

Approaching the Patient

Before Transferring the Patient

- Always inform the patient of what you are about to do.
- Ensure that you have the correct model and size of sling at hand if the patient has been assessed as requiring a sling.
- Before an attempt is made to move the patient, an assessment is performed by a qualified professional.

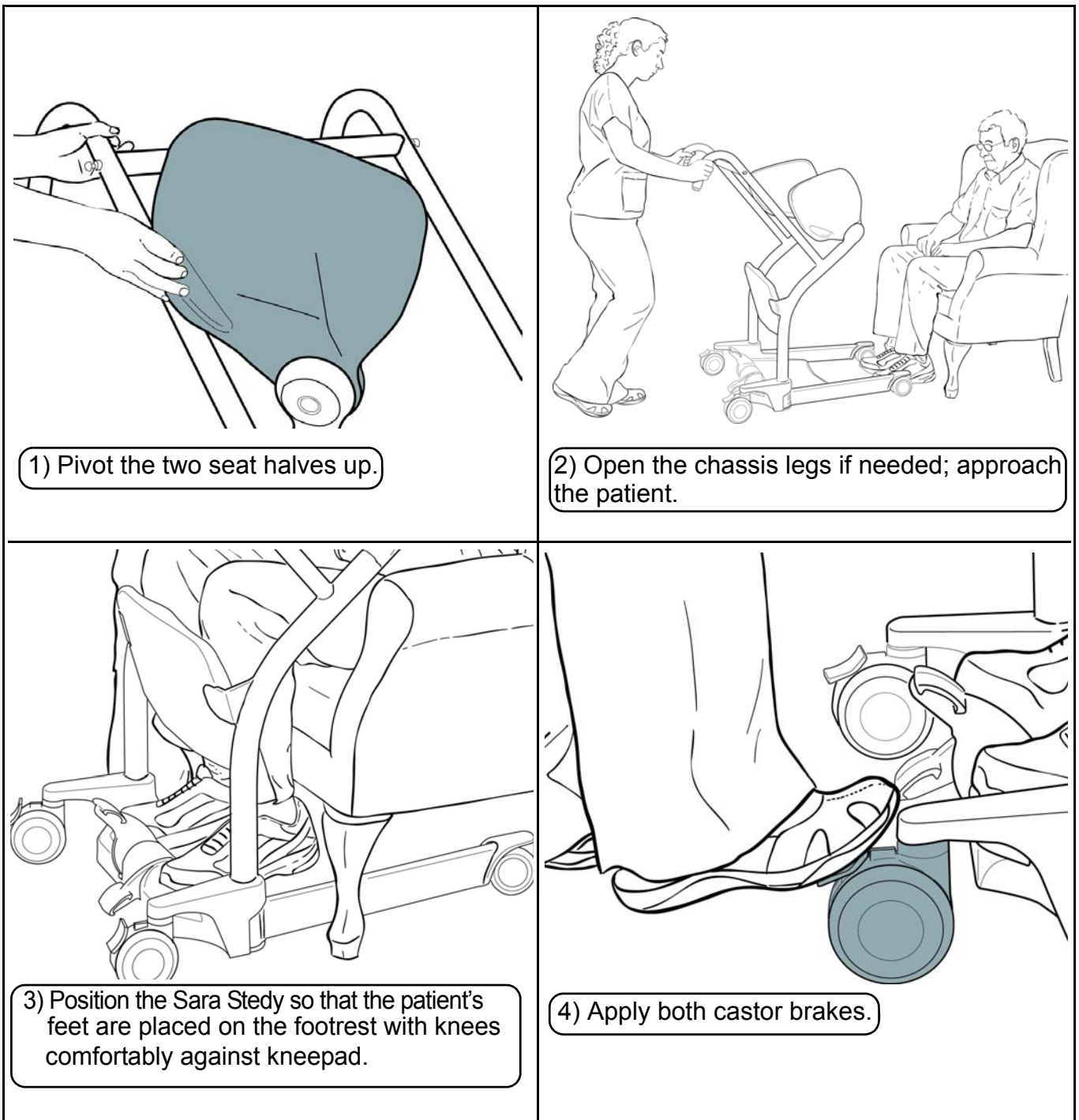

Fig. 9

How to Use the Sara Stedy

Transferring the Patient

Transferring the Patient from a Chair

- Help or encourage the patient to achieve the standing position.
- The patient's knees should stay in contact with the kneepad, and the patient should sit back on the seat halves during the transfer.

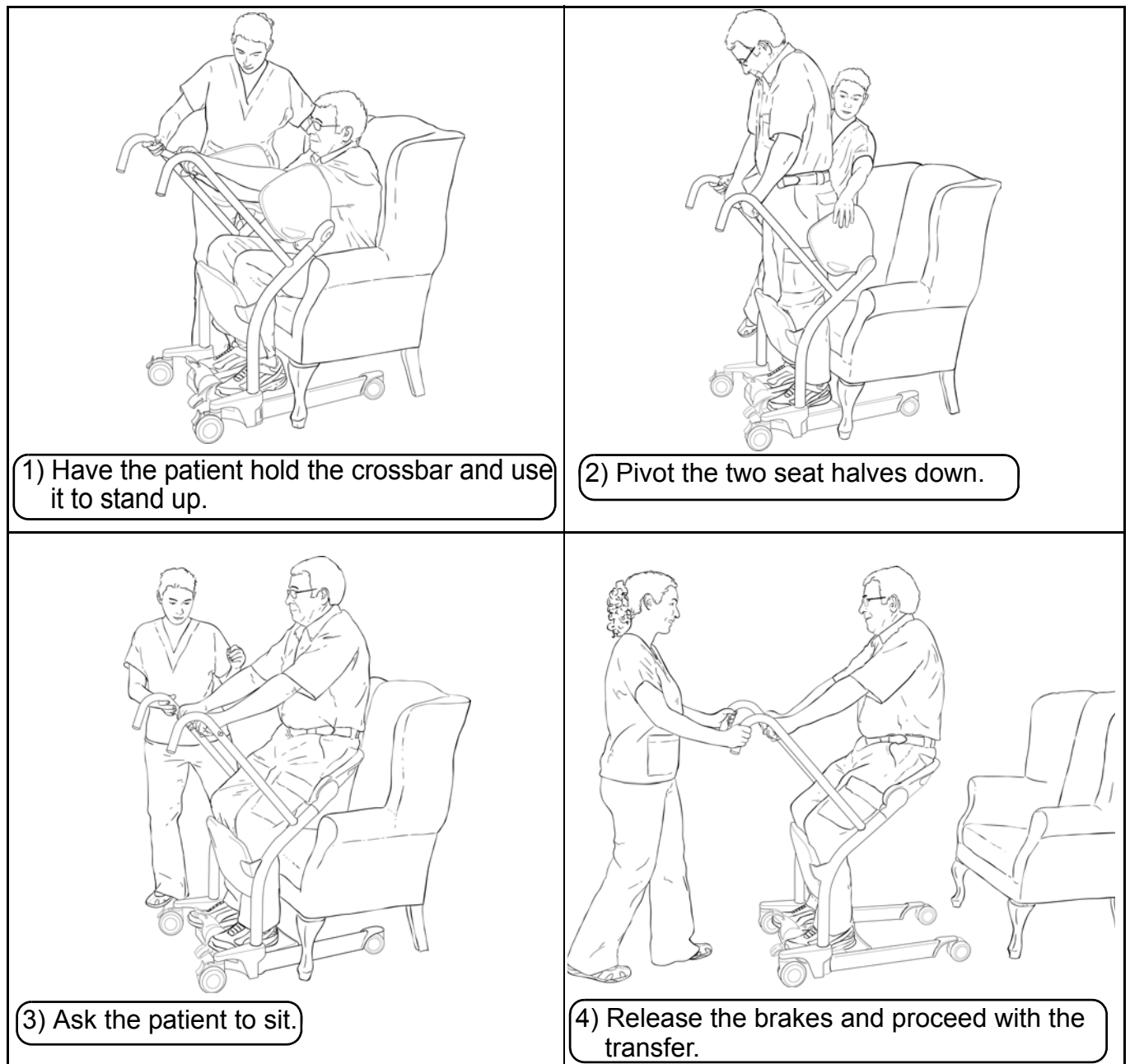

Fig. 10

How to Use the Sara Stedy

Transferring the Patient to a Chair

- Help or encourage the patient to achieve the sitting position.
- The patient's knees should stay in contact with the kneepad, and the patient should sit back on the seat halves during the transfer.

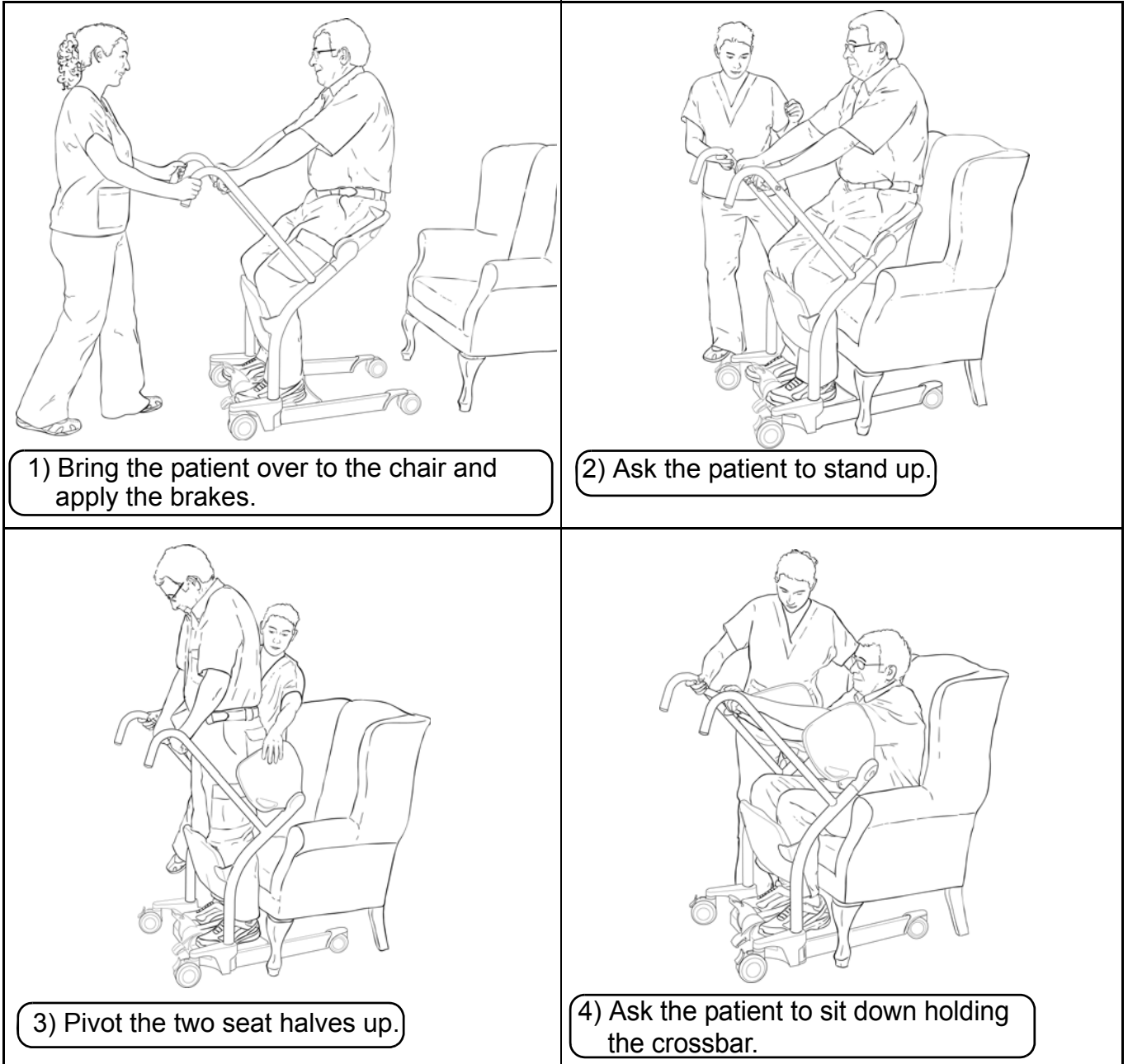

Fig. 11

How to Use the Sara Stedy

Transferring the Patient from a Wheelchair

- Make sure to apply the wheelchair brakes.
- Help or encourage the patient to achieve the standing position.
- The patient's knees should stay in contact with the kneepad, and the patient should sit back on the seat halves during the transfer.

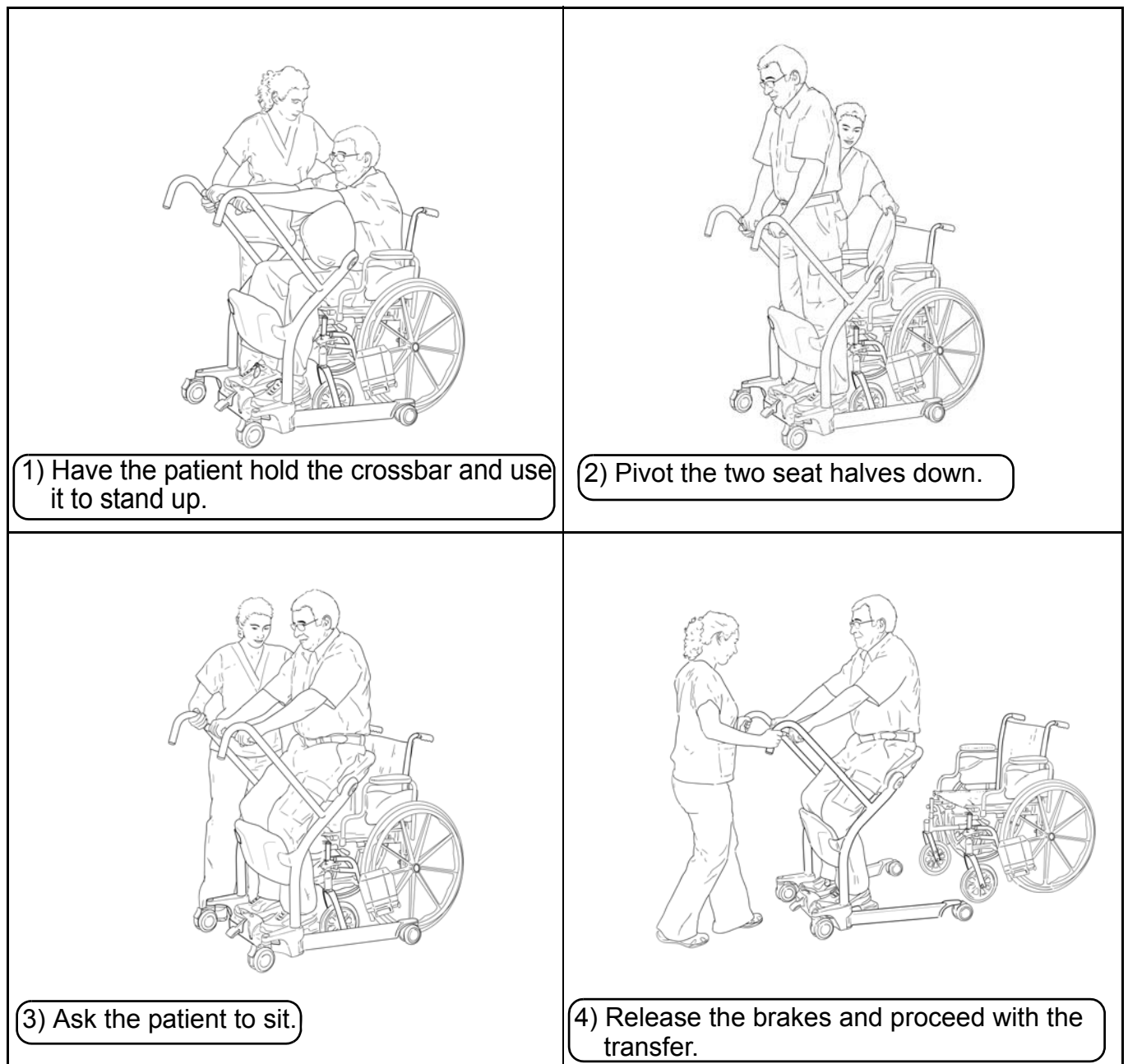

Fig. 12

How to Use the Sara Stedy

Transferring the Patient to a Wheelchair

- Make sure to apply the wheelchair brakes.
- Help or encourage the patient to achieve the sitting position.
- The patient's knees should stay in contact with the kneepad, and the patient should sit back on the seat halves during the transfer.

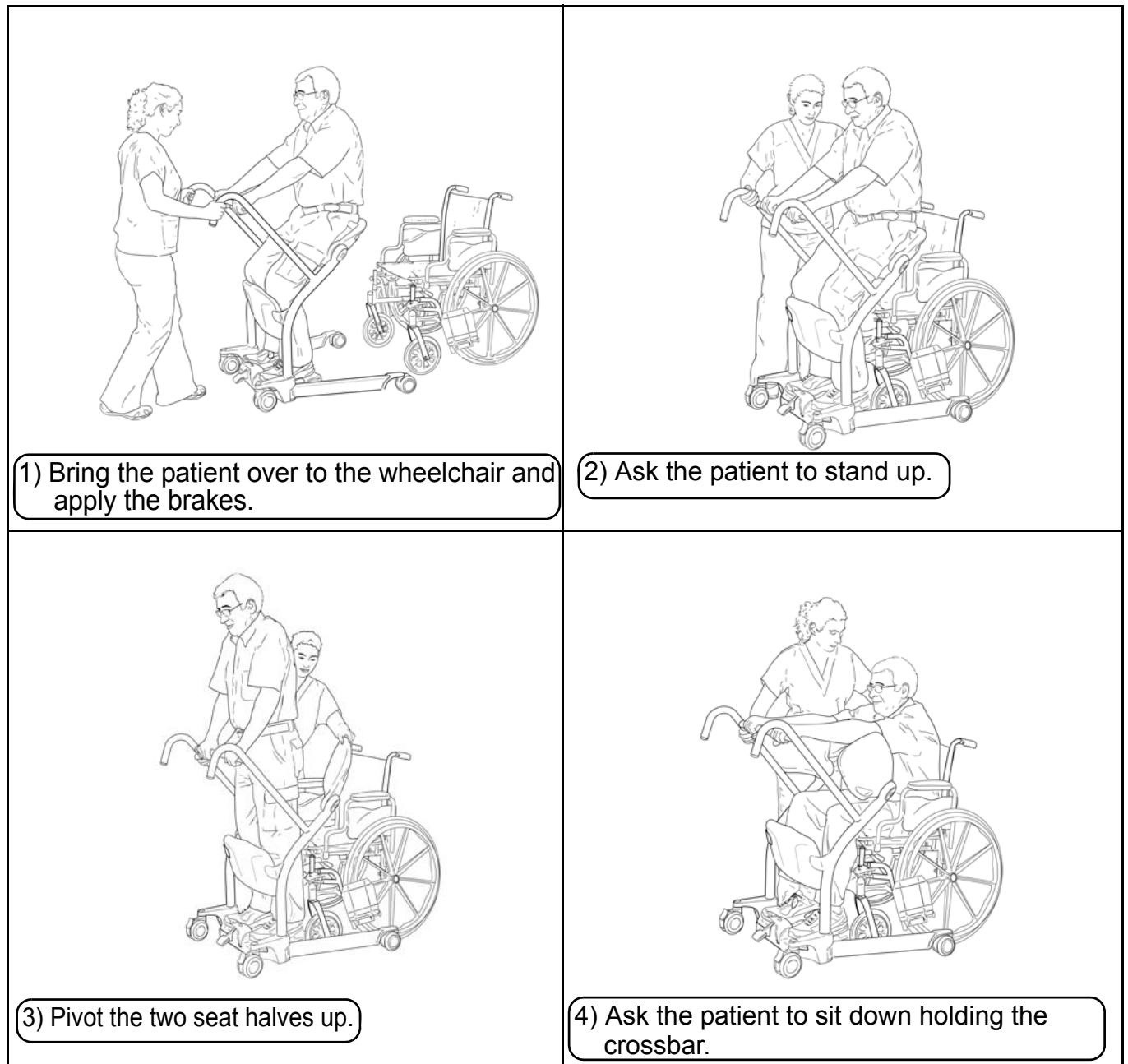

Fig. 13

How to Use the Sara Stedy

Transferring the Patient from a Bed

- Help or encourage the patient to achieve the standing position.
- The patient's knees should stay in contact with the kneepad, and the patient should sit back on the seat halves during the transfer.

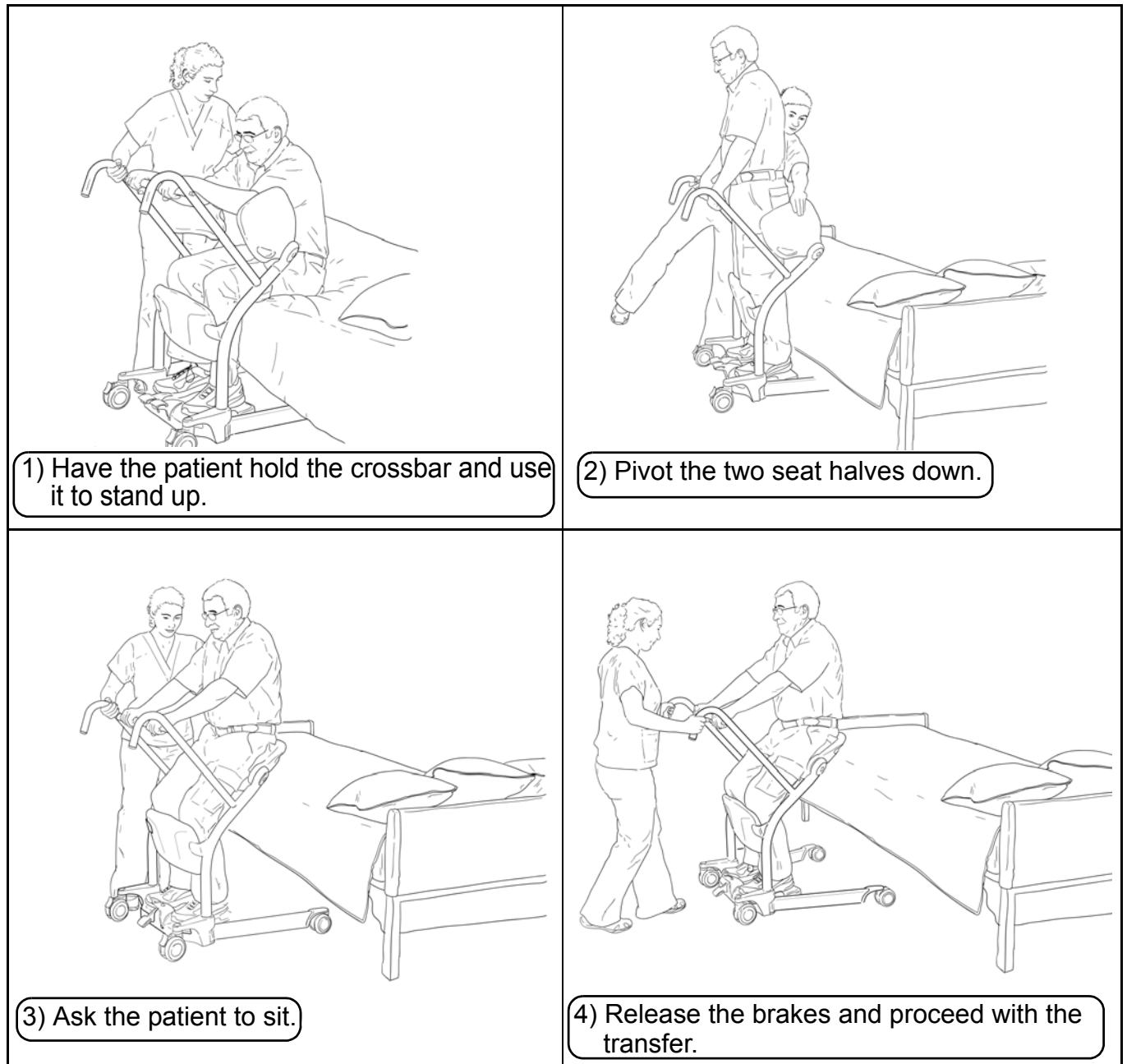

Fig. 14

How to Use the Sara Stedy

Transferring the Patient to a Bed

- Help or encourage the patient to achieve the sitting position.
- The patient's knees should stay in contact with the kneepad, and the patient should sit back on the seat halves during the transfer.

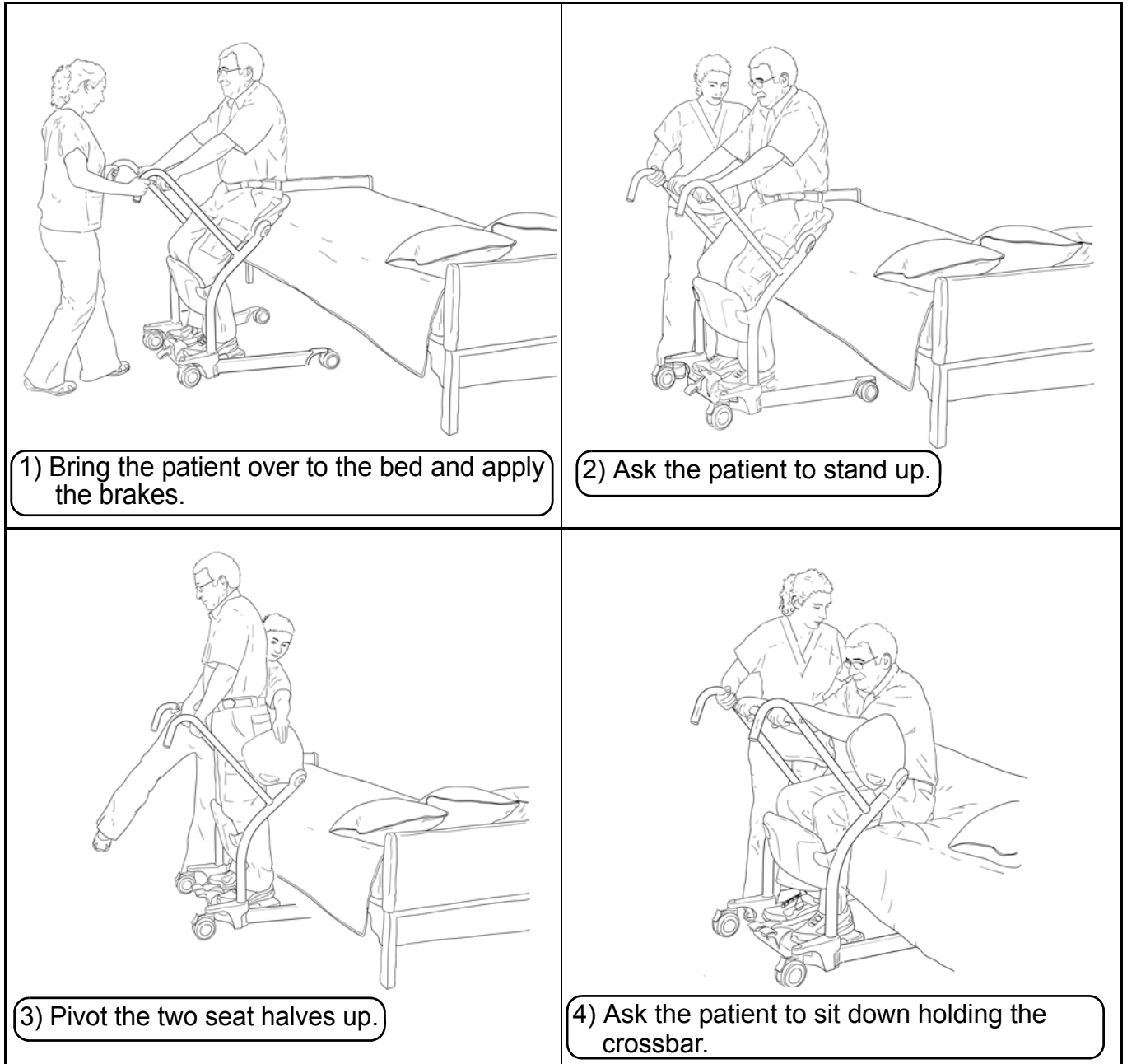

Fig. 15

How to Use the Sara Steady

Transferring the Patient from a Toilet

- Help or encourage the patient to achieve the standing position.
- The patient's knees should stay in contact with the kneepad, and the patient should sit back on the seat halves during the transfer.

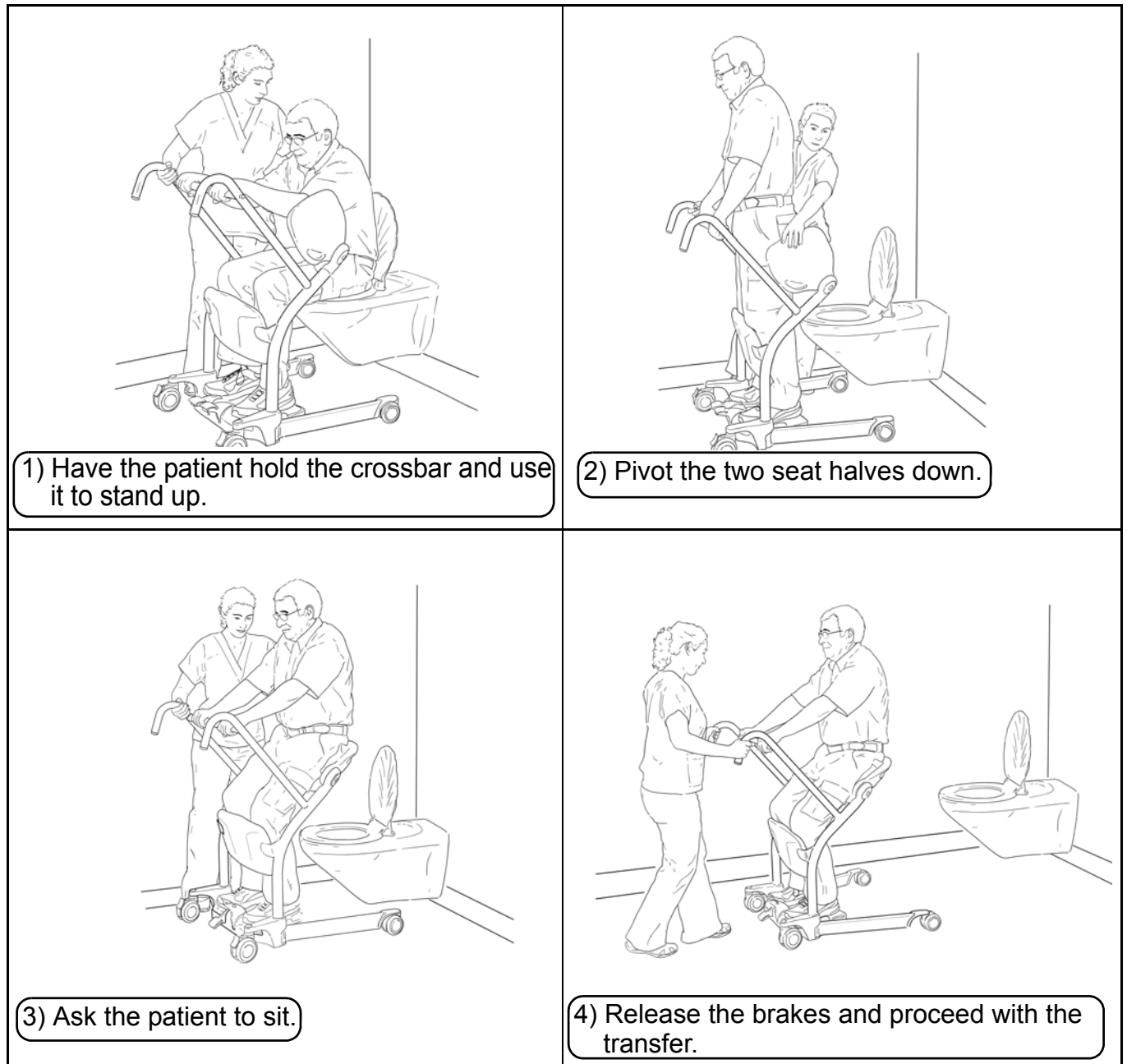

Fig. 16

How to Use the Sara Stedy

Transferring the Patient to a Toilet

- Help or encourage the patient to achieve the sitting position.
- The patient's knees should stay in contact with the kneepad, and the patient should sit back on the seat halves during the transfer.

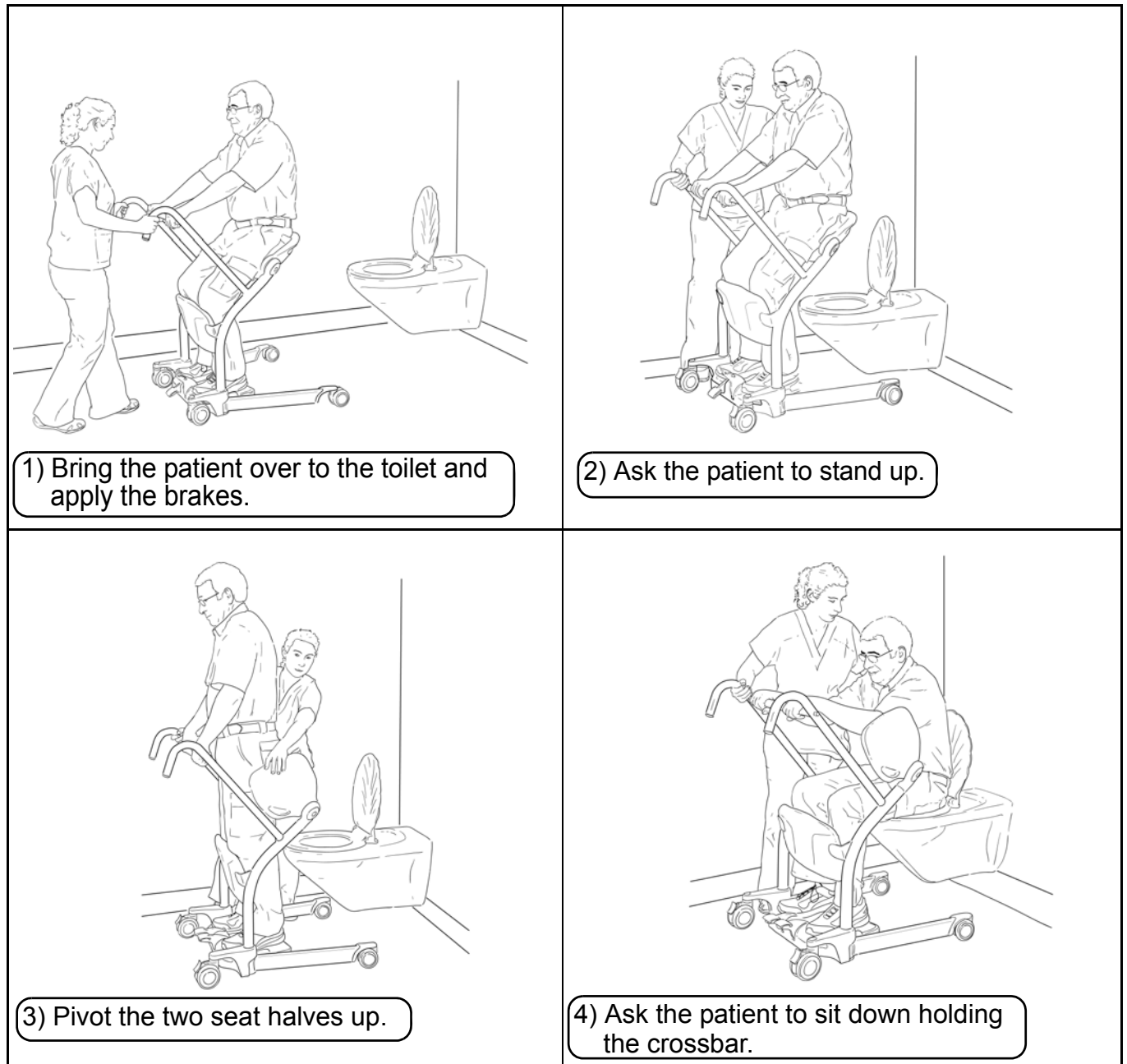

Fig. 17

Transferring the Patient at the Toilet

- Once the patient is in place, apply the castor brakes and ask the patient to stand.
- Remove the patient's clothing as necessary, then pivot the seat halves upwards to allow the patient to lower herself/himself onto the toilet seat. The Sara Stedy can thus function as a support frame, improving the patient's confidence.

How to Use the Sara Steady

Back Support Strap

Using the Back Support Strap

Use of this accessory is recommended where the patient would benefit from extra confidence and support. To use the back support strap:

- Position the strap at around 50 mm (2") above the waistline.
- Be careful not to pull the patient forward too much when connecting the support strap.

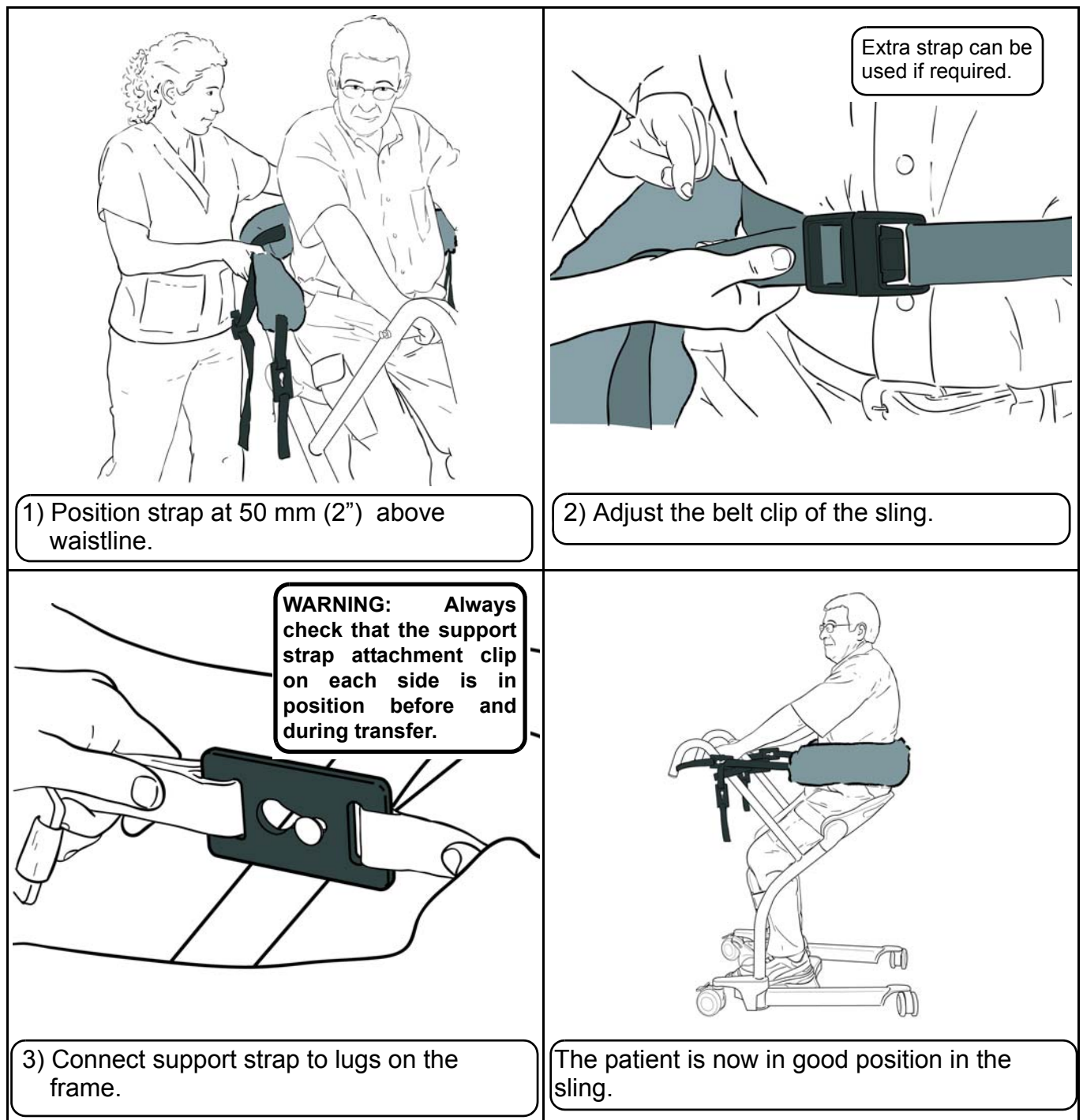

Fig. 18

Care and Maintenance

Preventive Maintenance Schedule

The equipment is subjected to wear and tear, and the following maintenance instructions must be acted upon when specified to ensure that the equipment remains within its original manufacturing specifications. Care and maintenance must be carried out in accordance with the preventive maintenance schedule below.

Customer obligations must be carried out by qualified personnel in accordance with the instructions in this manual.

WARNING: The maintenance described in the following checklist is the minimum that the manufacturer recommends. In some cases more frequent inspections should be carried out. Continuing to use this equipment without conducting regular inspections or when a fault is found will seriously compromise the safety of the user and of the patient. Local regulations and standards may be higher than those of the manufacturer. Service and preventive maintenance can be arranged with the manufacturer. Preventive maintenance specified in this manual can prevent accidents and reduce repair costs.

WARNING: Safety related maintenance and authorized service must be carried out by qualified personnel, fully trained in servicing procedures by ArjoHuntleigh, and equipped with correct tools. Failure to meet these requirements could result in personal injuries and/or unsafe equipment.

User Inspections

Action/check	Before every use	Every week	Every year
Transport device			
Carry out a visual inspection of all external parts. All functions must be tested for correct operation to ensure that no damage has occurred during previous use.	X		
Inspect for missing hardware or broken parts.	X		X
Inspect the sling lugs on the lift for damage or cracks.			X
Ensure that the castors are firmly secured to the chassis.		X	
Make sure all castors rotate freely and the two rear brakes lock.	X		
Check front and rear castors regularly for hair and debris; clean when necessary.		X	

Care and Maintenance

Action/check	Before every use	Every week	Every year
Examine all exposed parts, especially where there is personal contact with the patient's body. Make sure no cracks or sharp edges have developed that could cause patient or user injury or have become unhygienic. Replace where necessary and decontaminate.		X	
Make sure all instruction labels are firmly attached and in good readable condition. Replace when necessary.		X	
Make sure all external fittings are secure and that all screws and nuts are tight.		X	
Check the opening of the legs. The mechanism must open freely without using excessive force.		X	
Make sure that the anti-skid material is well glued to the chassis. Replace if needed.			X
Check leg opening mechanism under lift base. Make sure that mobile parts don't have excessive loose and are free of hair and debris.			X
Sling and hardware			
Check all sling attachments for sign of wear.	X		
Inspect sling material for wear or deterioration.	X		
Inspect sling straps for wear.	X		
Inspect for any defects or loose threads in the "stitched areas".	X		
Clean sling as indicated on the tag.			

WARNING: To avoid injuries that can be attributed to the use of inadequate parts, ArjoHuntleigh strongly advises and warns that only ArjoHuntleigh designated parts should be used on equipment and other appliances supplied by ArjoHuntleigh. Unauthorized modifications on any ArjoHuntleigh equipment may affect its safety. ArjoHuntleigh will not be held responsible for any accidents, incidents or lack of performance that occur as a result of any unauthorized modification to its products.

NOTE: If the product does not work as intended, immediately contact your local ArjoHuntleigh representative for support.

Care and Maintenance

Inspection and Cleaning

WARNING: It is recommended that your Sara Stedy and its accessories are regularly cleaned and/or disinfected between each use if necessary, or daily as a minimum. If the lift and/or equipment needs cleaning, or is suspected of being contaminated, follow the cleaning and/or disinfection procedures recommended below, before re-using the equipment.

To clean the Sara Stedy, wipe it down with a damp cloth using warm water and a disinfectant cleaner. Disinfectant wipes, supplied already impregnated with a 70 % v/v solution of isopropyl alcohol, can also be used.

Rub the lift vigorously when using the wipes, to promote an effective disinfection of its entire surface. Do not use phenol, chlorine or any other type of solvent that may damage the finish.

Sling Inspection and Care

See the documentation that comes with your sling.

Annual Inspection

The Sara Stedy and its accessories must be inspected annually by a qualified technician.

WARNING: The Sara Stedy and accessories must be serviced every 12 months as a minimum requirement (see "Care and Maintenance" section). Do not attempt to do the inspection unless you are qualified to do so.

Troubleshooting

Lift Trouble	Resolution
Poor maneuverability	<ul style="list-style-type: none">• Check castor for any damage or wear.• Remove hair and debris from castor.
Legs do not open or close	<ul style="list-style-type: none">• Check legs opening mechanism for damage. Call ArjoHuntleigh for replacement if needed.
Legs difficult to open or close	<ul style="list-style-type: none">• Check legs opening mechanism for damage. Call ArjoHuntleigh for replacement if needed.• Legs opening mechanism need lubrication. Call ArjoHuntleigh for service.
Noise during opening	<ul style="list-style-type: none">• Legs opening mechanism need lubrication. Call ArjoHuntleigh for service.
Seat difficult to open or close	<ul style="list-style-type: none">• Check for debris or hair in the seat pivot. Clean if needed.

Labels on the Sara Steady

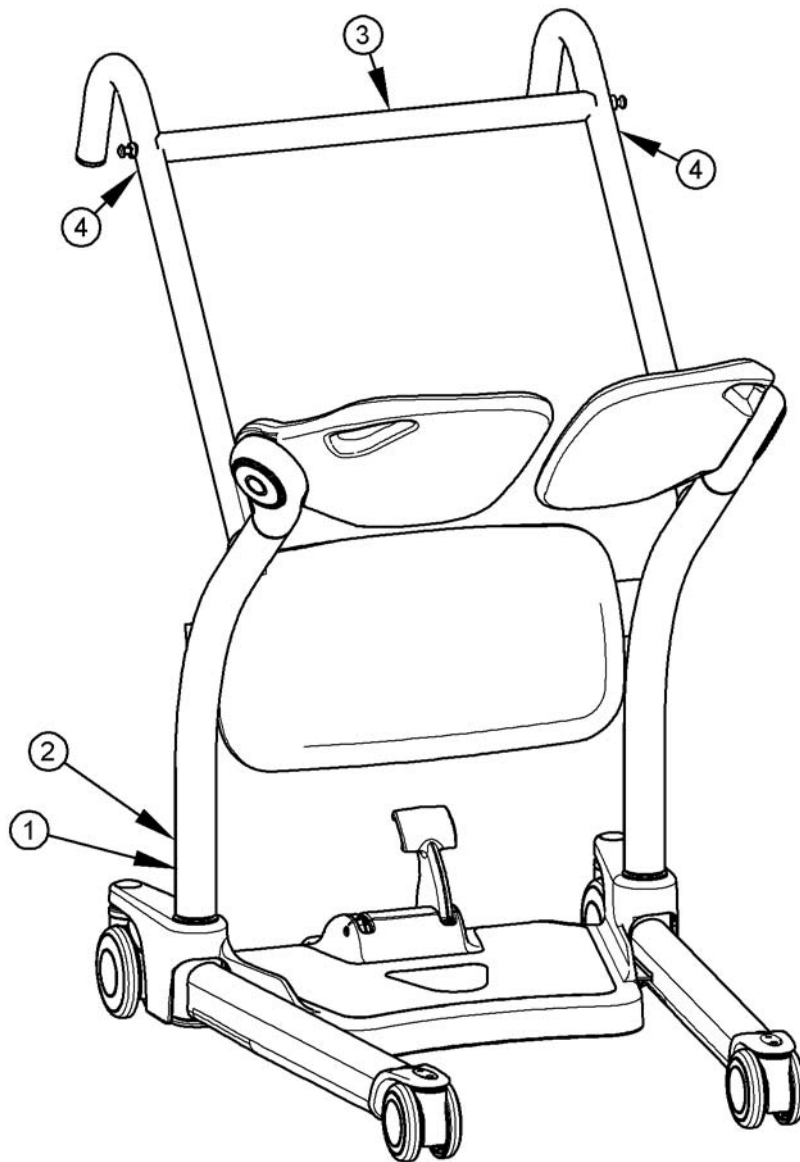

- 1) Serial number label
- 2) Product label
- 3) Product name
- 4) Sling attachment clip instruction label

Fig. 19

Technical Specifications

PRODUCT INFORMATION	Sara Steady
Weight, complete	29.4 kg (64.82 lb)
Lifting capacity	182 kg (400 lb)
Turning radius	1168 mm (46 in)
Minimum door requirement	630 mm (24.80 in)
Pedal operating force	< 300 N
OPERATION AND STORAGE CONDITIONS	
Ambient temperature range (lift)	Operation: 10 ° to 40 °C (+50 to +104 °F), Storage: - 40 ° to 70 °C (-40 to 158 °F)
Relative humidity range	Operation: 30 to 75 %, Storage: 10 to 80 %, incl. condensation
Atmospheric pressure range	Operation: 700 hPa to 1060 hPa, Storage: 500 hPa to 1060 hPa
RECYCLING	
Package	Recycleable cardboard
The lift	Separated and recycled

Technical Specifications

Lift Dimensions

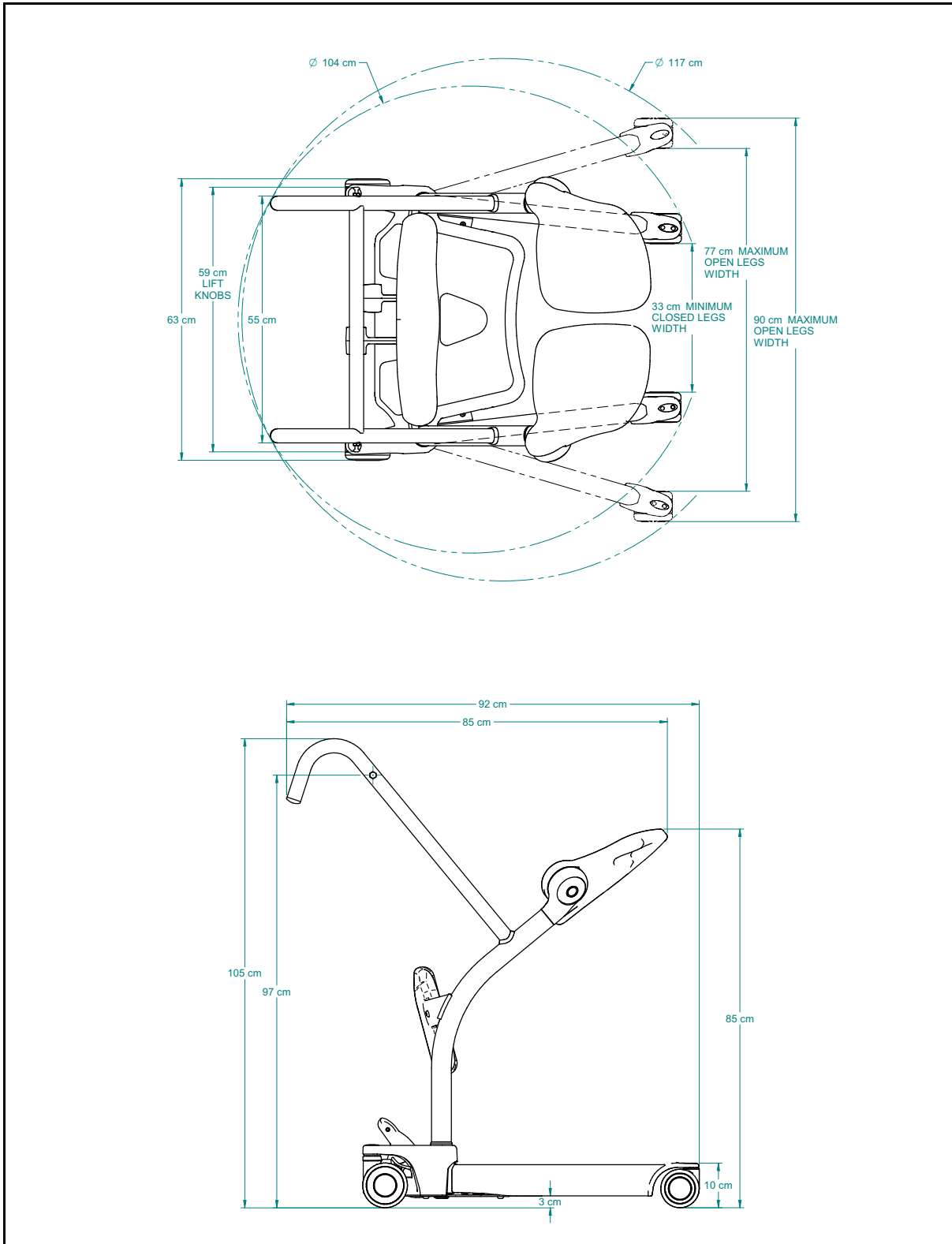

Fig. 20

AUSTRALIA

ArjoHuntleigh Pty Ltd
78, Forsyth street
O'Connor
AU-6163 Western Australia
Tel: +61 89337 4111
Free: +1 800 072 040
Fax: + 61 89337 9077

BELGIQUE / BELGIË

ArjoHuntleigh NV/SA
Evenbroekveld 16
BE-9420 ERPE-MERE
Tél/Tel: +32 (0) 53 60 73 80
Fax: +32 (0) 53 60 73 81
E-mail: info@arjohuntleigh.be

BRASIL

Maquet do Brasil Equipamentos Médicos Ltda
Rua Tenente Alberto Spicciati, 200
Barra Funda, 01140-130
SÃO PAULO, SP - BRASIL
Fone: +55 (11) 2608-7400
Fax: +55 (11) 2608-7410

CANADA

ArjoHuntleigh
90 Matheson Boulevard West
Suite 300
CA-MISSISSAUGA, ON, L5R 3R3
Tel/Tél: +1 905 238 7880
Free: +1 800 665 4831 Institutional
Free: +1 800 868 0441 Home Care
Fax: +1 905 238 7881
E-mail: info.canada@arjohuntleigh.com

ČESKÁ REPUBLIKA

ArjoHuntleigh s.r.o.
Hlinky 118
CZ-603 00 BRNO
Tel: +420 549 254 252
Fax: +420 541 213 550

DANMARK

ArjoHuntleigh A/S
Vassingerødvej 52
DK-3540 LYNGE
Tel: +45 49 13 84 86
Fax: +45 49 13 84 87
E-mail: info.dk@arjohuntleigh.com

DEUTSCHLAND

ArjoHuntleigh GmbH
Peter-Sander-Strasse 10
DE-55252 MAINZ-KASTEL
Tel: +49 (0) 6134 186 0
Fax: +49 (0) 6134 186 160
E-mail: info-de@arjohuntleigh.com

ΕΛΛΑΔΑ

C. Psimitis Co Ltd
Dimitriou Andr. 59
GR-16121 KAISARIANI ATTIKIS
Τηλ: 21 0724 36 68
Φάξ: 21 0721 55 53

ESPAÑA

ArjoHuntleigh Ibérica S.L.
Ctra. de Rubí, 88 1ª planta - A1
08173 Sant Cugat del Vallés
ES- BARCELONA 08173
Tel: +34 93 583 11 20
Fax: +34 93 583 11 22
E-mail: info.es@arjohuntleigh.com

FRANCE

ArjoHuntleigh SAS
2 Avenue Alcide de Gasperi
CS 70133
FR-59436 RONCQ CEDEX
Tél: +33 (0) 3 20 28 13 13
Fax: +33 (0) 3 20 28 13 14
E-mail : info.france@arjohuntleigh.com

HONG KONG

ArjoHuntleigh (Hong Kong) Ltd
1510-17, 15/F, Tower 2
Kowloon Commerce Centre
51 Kwai Cheong Road
Kwai Chung
HONG KONG
Tel: +852 2207 6363
Fax: +852 2207 6368

INTERNATIONAL

ArjoHuntleigh International Ltd.
ArjoHuntleigh House
Houghton Hall Park
Houghton Regis
UK-DUNSTABLE LU5 5XF
Tel: +44 (0) 1582 745 800
Fax: +44 (0) 1582 745 866
E-mail:
international@ArjoHuntleigh.com

ITALIA

ArjoHuntleigh S.p.A.
Via di Tor Vergata 432
IT-00133 ROMA
Tel: +39 (0) 6 87426211
Fax: +39 (0) 6 87426222
E-mail: Italy.promo@arjohuntleigh.com

NEDERLAND

ArjoHuntleigh Nederland BV
Biezenwei 21
4004 MB TIEL
Postbus 6116
4000 HC TIEL
Tel: +31 (0) 344 64 08 00
Fax: +31 (0) 344 64 08 85
E-mail: info.nl@arjohuntleigh.com

NEW ZEALAND

ArjoHuntleigh Ltd
41 Vestey Drive
Mount Wellington
NZ-AUCKLAND 1060
Tel: +64 (0) 9 573 5344
Free Call: 0800 000 151
Fax: +64 (0) 9 573 5384
E-mail: nz.info@ArjoHuntleigh.com

NORGE

ArjoHuntleigh Norway AS
Olaf Helset's vei 5
NO-0694 OSLO
Tel: +47 22 08 00 50
Faks: +47 22 57 06 52
E-mail: no.kundeservice@arjohuntleigh.com

ÖSTERREICH

ArjoHuntleigh GmbH
Dörrstrasse 85
AT-6020 INNSBRUCK
Tel: +43 (0) 512 204 160 0
Fax: +43 (0) 512 204 160 75

POLSKA

ArjoHuntleigh Polska Sp. z o.o.
ul. Ks Piotra Wawrzyniaka 2
PL-62-052 KOMORNIKI (Poznan)
Tel: +48 61 662 15 50
Fax: +48 61 662 15 90
E-mail: arjo@arjohuntleigh.com

PORTUGAL

ArjoHuntleigh em Portugal:
MAQUET Portugal, Lda. (Distribuidor Exclusivo)
Rua Poeta Bocage n.º 2 - 2G
PT-1600-233 Lisboa
Tel: +351 214 189 815
Fax: +351 214 177 413
E-mail: Portugal@arjohuntleigh.com

SUISSE / SCHWEIZ

ArjoHuntleigh AG
Fabrikstrasse 8
Postfach
CH-4614 HÄGENDORF
Tél/Tel: +41 (0) 61 337 97 77
Fax: +41 (0) 61 311 97 42

SUOMI

Oy Vestek AB
Martinkuja 4
FI-02270 ESPOO
Puh: +358 9 8870 120
E-mail: info@vestek.fi

SVERIGE

ARJO Scandinavia AB
Verkstadsvägen 5
Box 61
SE-241 21 ESLÖV
Tel: +46 (0) 10-494 7760
Fax: +46 (0) 413-138 76
E-mail: kundservice@arjohuntleigh.com

UNITED KINGDOM

ArjoHuntleigh UK
ArjoHuntleigh House
Houghton Hall Park
Houghton Regis
UK-DUNSTABLE LU5 5XF
Tel: +44 (0) 1582 745 700
Fax: +44 (0) 1582 745 745
E-mail:
sales.admin@ArjoHuntleigh.com

USA

ArjoHuntleigh Inc.
2349 W Lake Street Suite 250
US-Addison, IL 60101
Tel: +1 630 307 2756
Free: +1 800 323 1245 Institutional
Free: +1 800 868 0441 Home Care
Fax: +1 630 307 6195
E-mail: us.info@ArjoHuntleigh.com

ARJOHUNTLEIGH

GETINGE GROUP

GETINGE GROUP is a leading global provider of products and systems that contribute to quality enhancement and cost efficiency within healthcare and life sciences. We operate under the three brands of **ArjoHuntleigh**, **GETINGE** and **MAQUET**. **ArjoHuntleigh** focuses on patient mobility and wound management solutions. **GETINGE** provides solutions for infection control within healthcare and contamination prevention within life sciences. **MAQUET** specializes in solutions, therapies and products for surgical interventions and intensive care.

www.ArjoHuntleigh.com



ArjoHuntleigh AB
Hans Michelsensgatan 10
211 20 Malmö
SWEDEN



0 0 1 - 1 2 3 2 5 - E N